

5000W,5 - 250V Transient Voltage Suppressors

Features

- Very fast response time
- Glass passivated junction
- Excellent clamping capability
- Moisture sensitivity: level 1, per J-STD-020
- Available in unidirectional and bidirectional
- Plastic package has underwriters Laboratory Flammability Classification 94V-0
- 5000 W peak pulse power capability with a 10/1000 μ s waveform

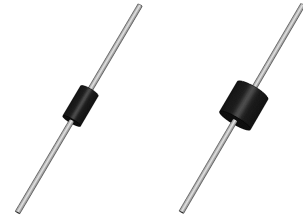

R-6/P600

Applications

- SMPS
- Adapters
- Monitor

Absolute Maximum Ratings ($T_A=25^\circ\text{C}$ unless otherwise noted)

Parameter	Symbol	Ratings	Unit
Peak power dissipation with a 10/1000us waveform	P_{PPM}	5000	W
Peak pulse current with a 10/1000us waveform	I_{PPM}	See Next Table	A
Power dissipation, on infinite heat sink at $T_L=75^\circ\text{C}$	P_D	8	W
Peak forward surge current, 8.3ms single half-sine wave	I_{FSM}	500	A
Operating junction and storage temperature range	T_J, T_{STG}	-55 to +175	$^\circ\text{C}$



Electrical Characteristics (TA = 25 °C unless otherwise noted)

Part Number (Uni)	Part Number (Bi)	Breakdown Voltage VBR (Volts)		Test Current I _T (mA)	Stand off Voltage V _{WM} (Volts)	Maximum reverse leakage at V _{WM} I _D (μA)	Maximum Peak Pulse Current I _{ppM} (A)	Maximum Clamping Voltage at I _{ppM} V _C (Volts)
		Min	Max					
5KP5.0	5KP5.0C	6.40	7.30	50	5	2000	521	9.6
5KP5.0A	5KP5.0CA	6.40	7.07	50	5	2000	543	9.2
5KP6.0	5KP6.0C	6.67	8.15	50	6	5000	439	11.4
5KP6.0A	5KP6.0CA	6.67	7.37	50	6	5000	485	10.3
5KP6.5	5KP6.5C	7.22	8.82	50	6.5	2000	407	12.3
5KP6.5A	5KP6.5CA	7.22	7.98	50	6.5	2000	446	11.2
5KP7.0	5KP7.0C	7.78	9.51	50	7	1000	376	13.3
5KP7.0A	5KP7.0CA	7.78	8.60	50	7	1000	417	12.0
5KP7.5	5KP7.5C	8.33	10.20	5.0	7.5	250	350	14.3
5KP7.5A	5KP7.5CA	8.33	9.21	5.0	7.5	250	388	12.9
5KP8.0	5KP8.0C	8.89	10.90	5.0	8	150	333	15.0
5KP8.0A	5KP8.0CA	8.89	9.83	5.0	8	150	368	13.6
5KP8.5	5KP8.5C	9.44	11.50	5.0	8.5	50	314	15.9
5KP8.5A	5KP8.5CA	9.44	10.40	5.0	8.5	50	347	14.4
5KP9.0	5KP9.0C	10.0	12.20	5.0	9	20	296	16.9
5KP9.0A	5KP9.0CA	10.0	11.10	5.0	9	20	325	15.4
5KP10	5KP10C	11.1	13.6	5.0	10	15	266	18.8
5KP10A	5KP10CA	11.1	12.3	5.0	10	15	294	17.0
5KP11	5KP11C	12.2	14.9	5.0	11	10	249	20.1
5KP11A	5KP11CA	12.2	13.5	5.0	11	10	275	18.2
5KP12	5KP12C	13.3	16.3	5.0	12	5.0	227	22.0
5KP12A	5KP12CA	13.3	14.7	5.0	12	5.0	251	19.9
5KP13	5KP13C	14.4	17.6	5.0	13	2.0	210	23.8
5KP13A	5KP13CA	14.4	15.9	5.0	13	2.0	233	21.5
5KP14	5KP14C	15.6	19.1	5.0	14	2.0	194	25.8
5KP14A	5KP14CA	15.6	17.2	5.0	14	2.0	216	23.2
5KP15	5KP15C	16.7	20.4	5.0	15	2.0	186	26.9
5KP15A	5KP15CA	16.7	18.5	5.0	15	2.0	205	24.4
5KP16	5KP16C	17.8	21.8	5.0	16	2.0	174	28.8
5KP16A	5KP16CA	17.8	19.7	5.0	16	2.0	192	26.0
5KP17	5KP17C	18.9	23.1	5.0	17	2.0	164	30.5
5KP17A	5KP17CA	18.9	20.9	5.0	17	2.0	181	27.6
5KP18	5KP18C	20.0	24.4	5.0	18	2.0	155	32.2
5KP18A	5KP18CA	20.0	22.1	5.0	18	2.0	171	29.2



Electrical Characteristics (TA = 25 °C unless otherwise noted)

Part Number (Uni)	Part Number (Bi)	Breakdown Voltage VBR (Volts)		Test Current I _T (mA)	Stand off Voltage V _{WM} (Volts)	Maximum reverse leakage at V _{WM} I _D (μA)	Maximum Peak Pulse Current I _{ppM} (A)	Maximum Clamping Voltage at I _{ppM} V _C (Volts)
		Min	Max					
5KP20	5KP20C	22.2	27.1	5.0	20	2.0	140	35.8
5KP20A	5KP20CA	22.2	24.5	5.0	20	2.0	154	32.4
5KP22	5KP22C	24.4	29.8	5.0	22	2.0	127	39.4
5KP22A	5KP22CA	24.4	26.9	5.0	22	2.0	141	35.5
5KP24	5KP24C	26.7	32.6	5.0	24	2.0	116	43.0
5KP24A	5KP24CA	26.7	29.5	5.0	24	2.0	129	38.9
5KP26	5KP26C	28.9	35.3	5.0	26	2.0	107	46.6
5KP26A	5KP26CA	28.9	31.9	5.0	26	2.0	119	42.1
5KP28	5KP28C	31.1	38.0	5.0	28	2.0	100	50.1
5KP28A	5KP28CA	31.1	34.4	5.0	28	2.0	110	45.4
5KP30	5KP30C	33.3	40.7	5.0	30	2.0	93.5	53.5
5KP30A	5KP30CA	33.3	36.8	5.0	30	2.0	103	48.4
5KP33	5KP33C	36.7	44.9	5.0	33	2.0	84.7	59.0
5KP33A	5KP33CA	36.7	40.6	5.0	33	2.0	93.8	53.3
5KP36	5KP36C	40.0	48.9	5.0	36	2.0	77.8	64.3
5KP36A	5KP36CA	40.0	44.2	5.0	36	2.0	86.1	58.1
5KP40	5KP40C	44.4	54.3	5.0	40	2.0	70.0	71.4
5KP40A	5KP40CA	44.4	49.1	5.0	40	2.0	77.5	64.5
5KP43	5KP43C	47.8	58.4	5.0	43	2.0	65.2	76.7
5KP43A	5KP43CA	47.8	52.8	5.0	43	2.0	72.0	69.4
5KP45	5KP45C	50.0	61.1	5.0	45	2.0	62.3	80.3
5KP45A	5KP45CA	50.0	55.3	5.0	45	2.0	68.8	72.7
5KP48	5KP48C	53.3	65.2	5.0	48	2.0	58.5	85.5
5KP48A	5KP48CA	53.3	58.9	5.0	48	2.0	64.6	77.4
5KP51	5KP51C	56.7	69.3	5.0	51	2.0	54.9	91.1
5KP51A	5KP51CA	56.7	62.7	5.0	51	2.0	60.7	82.4
5KP54	5KP54C	60.0	73.3	5.0	54	2.0	51.9	96.3
5KP54A	5KP54CA	60.0	66.3	5.0	54	2.0	57.4	87.1
5KP58	5KP58C	64.4	78.7	5.0	58	2.0	48.5	103
5KP58A	5KP58CA	64.4	71.2	5.0	58	2.0	53.4	93.6
5KP60	5KP60C	66.7	81.5	5.0	60	2.0	46.7	107
5KP60A	5KP60CA	66.7	73.7	5.0	60	2.0	51.7	96.8
5KP64	5KP64C	71.1	86.9	5.0	64	2.0	43.9	114
5KP64A	5KP64CA	71.1	78.6	5.0	64	2.0	48.5	103



Electrical Characteristics (TA = 25 °C unless otherwise noted)

Part Number (Uni)	Part Number (Bi)	Breakdown Voltage VBR (Volts)		Test Current I _T (mA)	Stand off Voltage V _{WM} (Volts)	Maximum reverse leakage at V _{WM} I _D (μA)	Maximum Peak Pulse Current I _{PPM} (A)	Maximum Clamping Voltage at I _{PPM} V _C (Volts)
		Min	Max					
5KP70	5KP70C	77.8	95.1	5.0	70	2.0	40.0	125
5KP70A	5KP70CA	77.8	86.0	5.0	70	2.0	44.2	113
5KP75	5KP75C	83.3	102	5.0	75	2.0	37.3	134
5KP75A	5KP75CA	83.3	92.1	5.0	75	2.0	41.3	121
5KP78	5KP78C	86.7	106	5.0	78	2.0	36.0	139
5KP78A	5KP78CA	86.7	95.8	5.0	78	2.0	39.7	126
5KP85	5KP85C	94.4	115	5.0	85	2.0	33.1	151
5KP85A	5KP85CA	94.4	104	5.0	85	2.0	36.5	137
5KP90	5KP90C	100	122	5.0	90	2.0	31.3	160
5KP90A	5KP90CA	100	111	5.0	90	2.0	34.2	146
5KP100	5KP100C	111	136	5.0	100	2.0	27.9	179
5KP100A	5KP100CA	111	123	5.0	100	2.0	30.9	162
5KP110	5KP110C	122	149	5.0	110	2.0	25.5	196
5KP110A	5KP110CA	122	135	5.0	110	2.0	28.2	177
5KP120A	5KP120CA	133	147	5.0	120	2.0	26.4	193
5KP130A	5KP130CA	144	159	5.0	130	2.0	24.4	209
5KP150A	5KP150CA	167	185	5.0	150	2.0	21.0	243
5KP160A	5KP160CA	178	197	5.0	160	2.0	19.7	259
5KP170A	5KP170CA	189	209	5.0	170	2.0	18.5	275
5KP180A	5KP180CA	200	221	5.0	180	2.0	17.5	292
5KP190A	5KP190CA	211	233	5.0	190	2.0	16.5	310
5KP200A	5KP200CA	222	246	5.0	200	2.0	15.5	329.2
5KP210A	5KP210CA	233	258	5.0	210	2.0	14.6	349.5
5KP220A	5KP220CA	244	270	5.0	220	2.0	13.7	371.1
5KP250A	5KP250CA	277	306	5.0	250	2.0	12.0	425

Note:

- Valid provided that leads at a distance of 9.5 mm from case are kept at ambient temperature.

Ratings and Characteristics Curves

($T_A = 25^\circ\text{C}$ unless otherwise noted)

FIG.1-Peak Pulse Power Rating Curve

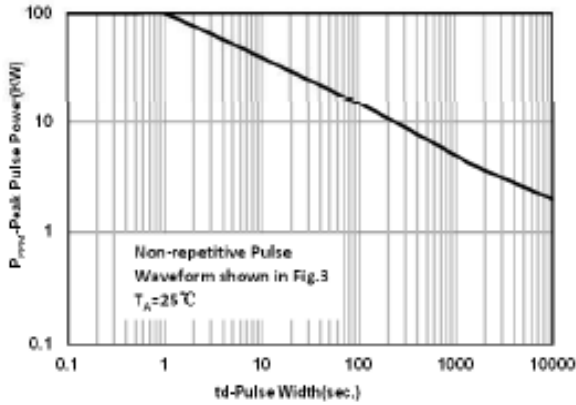

FIG.2-Pulse Derating Curve

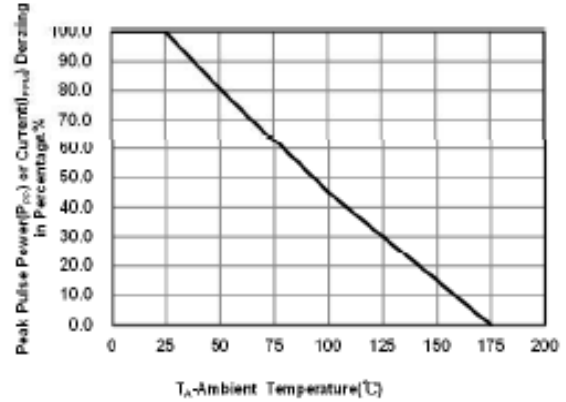

FIG.3-Pulse Waveform

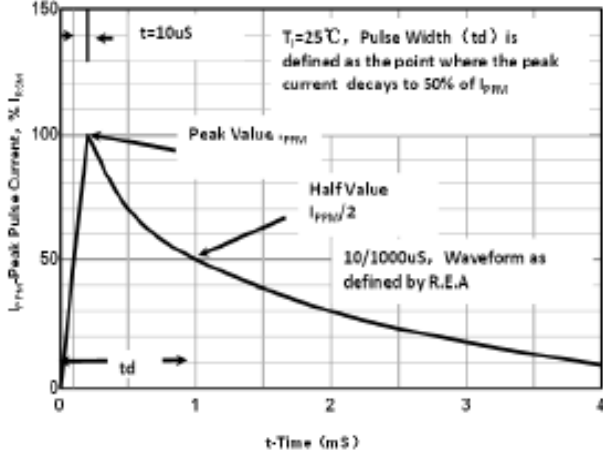

FIG.4-Typ Junction Capacitance Uni-Directional

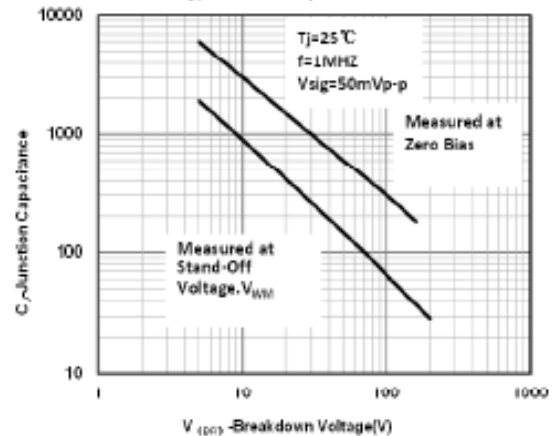

FIG5-Steady State Power Derating Curve

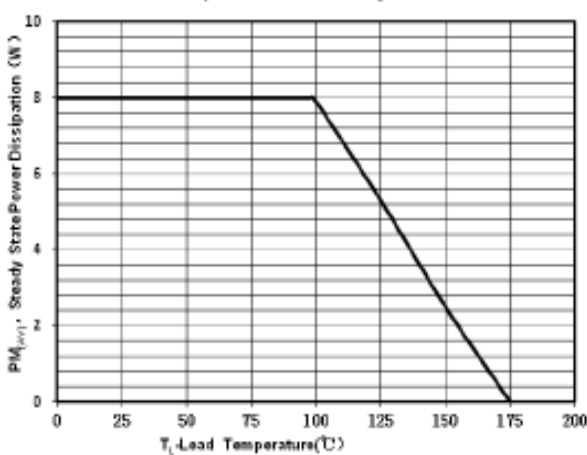
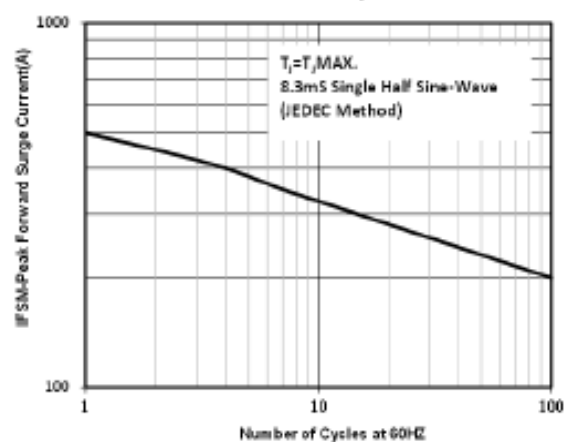

FIG6-Max.Non-Repetitive Forward Surge Current Uni-Directional Only



Package Outline Dimensions

in inches (millimeters)

R-6/P600

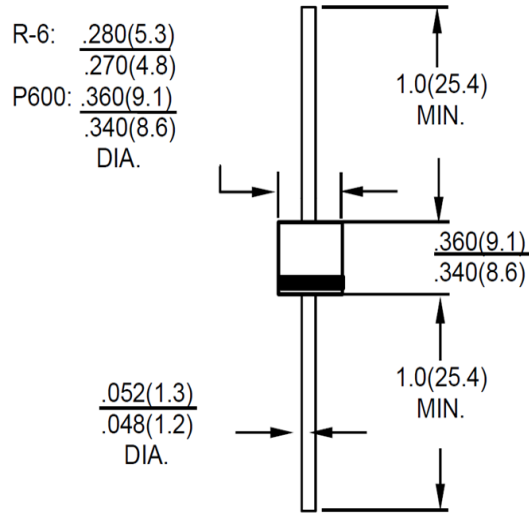

Dimensions in inches and (millimeters)

Revision History

Document Version	Date of release	Description of changes
Rev.A	2021.06.15	Released Datasheet
Rev.B	2023.11.28	Modify document format

Disclaimers

These materials are intended as a reference to assist our customers in the selection of the Suzhou Good-Ark product best suited to the customer's application; they do not convey any license under any intellectual property rights, or any other rights, belonging to Suzhou Good-Ark Electronics Co., Ltd. or a third party.

Suzhou Good-Ark Electronics Co., Ltd. assumes no responsibility for any damage, or infringement of any third-party's rights, originating in the use of any product data, diagrams, charts, programs, algorithms, or circuit application examples contained in these materials.

All information contained in these materials, including product data, diagrams, charts, programs and algorithms represents information on products at the time of publication of these materials, and are subject to change by Suzhou Good-Ark Electronics Co., Ltd. without notice due to product improvements or other reasons. It is therefore recommended that customers contact Suzhou Good-Ark Electronics Co., Ltd. or an authorized Suzhou Good-Ark Electronics Co., Ltd. for the latest product information before purchasing a product listed herein. The information described here may contain technical inaccuracies or typographical errors. Suzhou Good-Ark Electronics Co., Ltd. assumes no responsibility for any damage, liability, or other loss rising from these inaccuracies or errors. Please also pay attention to information published by Suzhou Good-Ark Electronics Co., Ltd. by various means, including our website home page.

(<http://www.goodark.com>)

When using any or all of the information contained in these materials, including product data, diagrams, charts, programs, and algorithms, Please be sure to evaluate all information as a total system before making a final decision on the applicability of the information and products. Suzhou Good-Ark Electronics Co., Ltd. assumes no responsibility for any damage, liability or other loss resulting from the information contained herein.

The prior written approval of Suzhou Good-Ark Electronics Co., Ltd. is necessary to reprint or reproduce in whole or in part these materials.

Please contact Suzhou Good-Ark Electronics Co., Ltd. or an authorized distributor for further details on these materials or the products contained herein.